

Seat Innovation



Pilot Chairs



Operator Chairs



Passenger Seats



About Us

The company, operating under the name Seat Innovation, serves as an umbrella organization to manage the design, production, marketing, sale, and delivery of Alu Design's pilot- and operator chairs, and Modell-Møbler's passenger seating.

Both brands are recognised by customers and shipyards around the world for providing excellent products and developing seating solutions that deliver quality, innovative design, comfort, structural strength, and durability.

Both companies have a recognised track record of innovation. With origins that date back to the 1950s, Modell-Møbler pioneered injection plastic moulding, a technology that inspired designers around the world, including the Danish designer, Arne Jacobsen, who created the iconic "Egg Chair."

Alu Design's futuristic bridge chairs have been featured in television and film action and sci-fi series, including the Star Trek, Transformers and Marvel Cinematic Universe franchises.

Seat Innovation is a single source supplier of pilot-, operator- and passenger seating solutions for the maritime, offshore and leisure craft industries. Creating the industry's first 'bow to stern' premium seating supplier.

S. E. & O.

BECAUSE OF CONTINUED PRODUCT IMPROVEMENT, WE RESERVE THE RIGHT TO MAKE CHANGES. SPECIFICATION CAN BE CHANGED AT ANY TIME. PLEASE CONTACT US FOR UPDATED SPECIFICATIONS BEFORE ORDERING.

CONTENT

6	SPECIFICATIONS	13	3000 FC
7	SPECIFICATIONS	14	OP 01
8	ALUTECH SERIES	15	ACCESSORIES & BESPOKE SOLUTION
9	ALUTECH 200	16	MANUAL DECK RAILS
10	OP 50/60/70/80	17	ELECTRICAL DECK RAILS
11	S12	18	ALU IN HOLLYWOOD
12	OPL	19	ALU IN HOLLYWOOD

CONTENT

20	BAHAMA STD	26	SENJA HIGH
21	BAHAMA HS	27	SENJA MIDI
22	BAHAMA DIPLOMAT	28	SENJA CREW
23	BAHAMA EXTENDED	29	OUTDOOR BENCHES
24	BAHAMA EDGE	30	CONTACT US
25	SENJA HS		

SPECIFICATIONS

ALUTECH 300/ 400/ 500 & 600

Article number	Sitting height	Max width	Weight	Footrest	Office base (option)	Flatback (option)	HSC
320(420)	420-490 mm	650 mm	38 kg		x	Alutech 460	x
325(425)	550-750 mm	650 mm	49 kg	x	x	Alutech 465	x
330(430)	630-880 mm	650 mm	50 kg	x	x	Alutech 470	x
340(440)	730-980 mm	650 mm	51 kg	x	x	Alutech 480	x
350(450)	830-1030 mm	650 mm	52 kg	x	x	Alutech 490	x
620	420-490 mm	650 mm	39 kg		x		x
625	550-750 mm	650 mm	49 kg	x	x		x
630	630-880 mm	650 mm	51 kg	x	x		x
640	730-980 mm	650 mm	52 kg	x	x		x
650	830-1030 mm	650 mm	53 kg	x	x		x
620-5(520)	420-490 mm	710 mm	43 kg		x	Alutech 560	x
625-5(525)	550-750 mm	710 mm	53 kg	x	x	Alutech 565	x
630-5(530)	630-880 mm	710 mm	54 kg	x	x	Alutech 570	x
640-5(540)	730-980 mm	710 mm	55 kg	x	x	Alutech 580	x
650-5(550)	830-1030 mm	710 mm	56 kg	x	x	Alutech 590	x

SPECIFICATIONS

ALUTECH 200, OPL, OP, S12

Article number	Sitting height	Width	Weight	Footrest	Office base (option)	Flatback (option)	HSC
220	400-500 mm	660 mm	25 kg		x	Alutech 265	x
230	550-750 mm	660 mm	28 kg	x	x	Alutech 270	x
240	650-850 mm	660 mm	29 kg	x	x	Alutech 280	x
250	750-950 mm	660 mm	30 kg	x	x	Alutech 290	x
260	850-1050 mm	660 mm	31 kg	x	x	Alutech 295	x
OPL620	420-490 mm	880 mm	58 kg				x
OPL625	550-750 mm	880 mm	71 kg	x			x
OPL630	630-880 mm	880 mm	72 kg	x			x
OPL640	730-980 mm	880 mm	73 kg	x			x
OPL650	830-1030 mm	880 mm	74 kg	x			x
OP50	600-800 mm	1082 mm	124 kg	x			
OP60	600-800 mm	1082 mm	128 kg	x			
OP70	600-800 mm	1172 mm	130 kg	x			
OP80	600-800 mm	1225 mm	134 kg	x			
S12	615-815 mm	1082 mm	118 kg	x			

ALUTECH SERIES

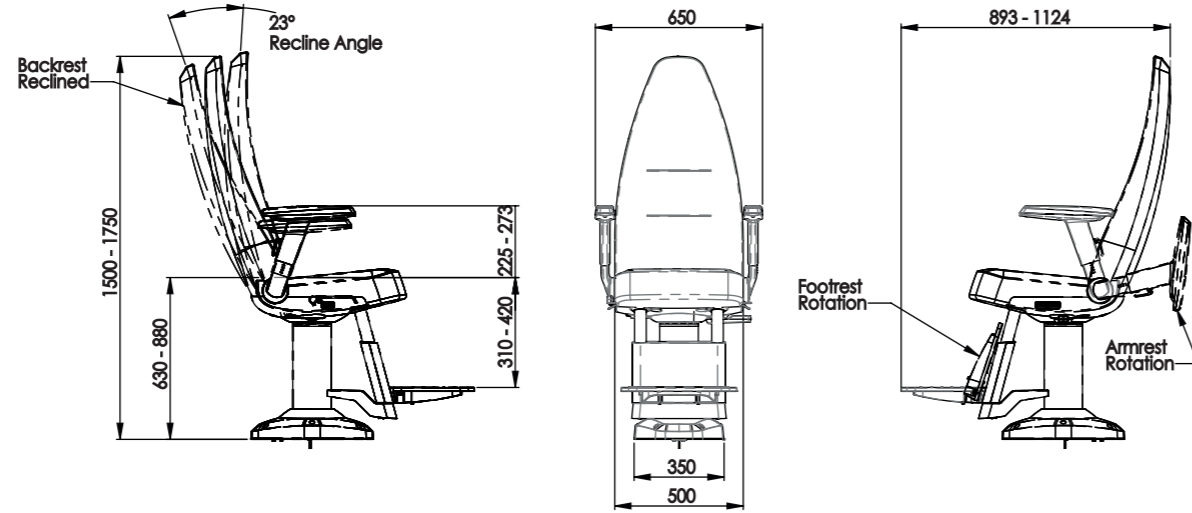

DESIGN AND FEATURES

- Reclining backrest
- Adjustable lumbar support
- Height adjustable or fixed armrests
- Flip back armrests
- Optional armrest attachments for control equipment and cup holders etc.
- Cable routing is possible through the chair and center column
- Pneumatic height adjustment
- Shock absorbing column
- Optional electric height adjustment
- Pneumatic height adjustment of footrest
- Fold up footrest
- Chair rotation
- Footrest rotates with chair and is supported by the column for stability
- Available with hardback in high gloss finish
- HSC 2000 – Annex 10 approved

DECK RAIL OPTIONS

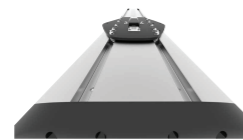

SURFACE MOUNT

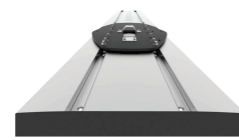

FLUSH MOUNT



SURFACE MOUNT



FLUSH MOUNT



ALUTECH 200

Seat Innovation

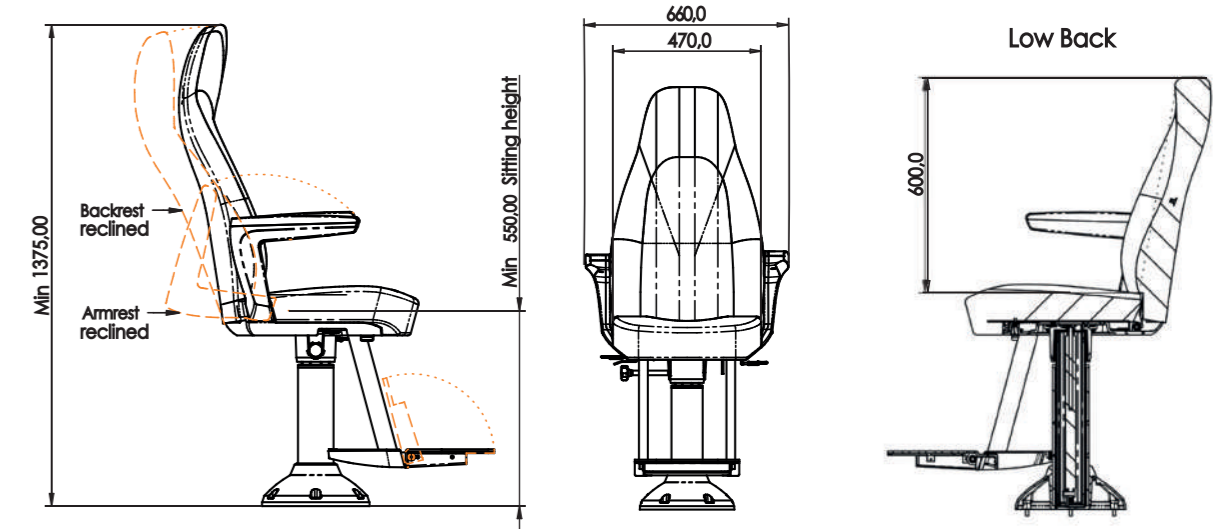

DESIGN AND FEATURES

- Reclining backrest
- Flip back armrest
- Pneumatic height adjustment
- Shock absorbing column
- Fold up footrest
- Chair rotation
- Footrest rotates with chair and is supported by column for stability
- Available with high and low seat back
- HSC 2000 – Annex 10 approved

DECK RAIL OPTIONS

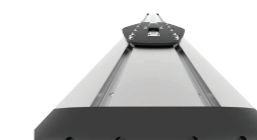

SURFACE MOUNT

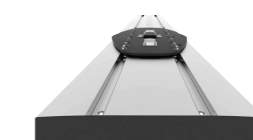

FLUSH MOUNT



SURFACE MOUNT



FLUSH MOUNT

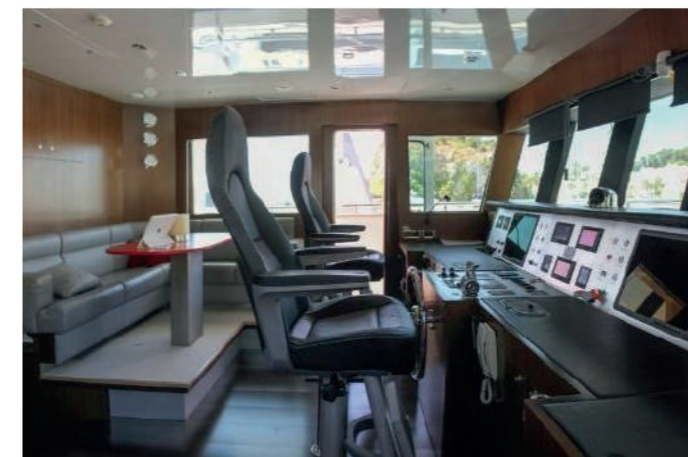

OP 50/60/65/70/80

alu
Be seated.

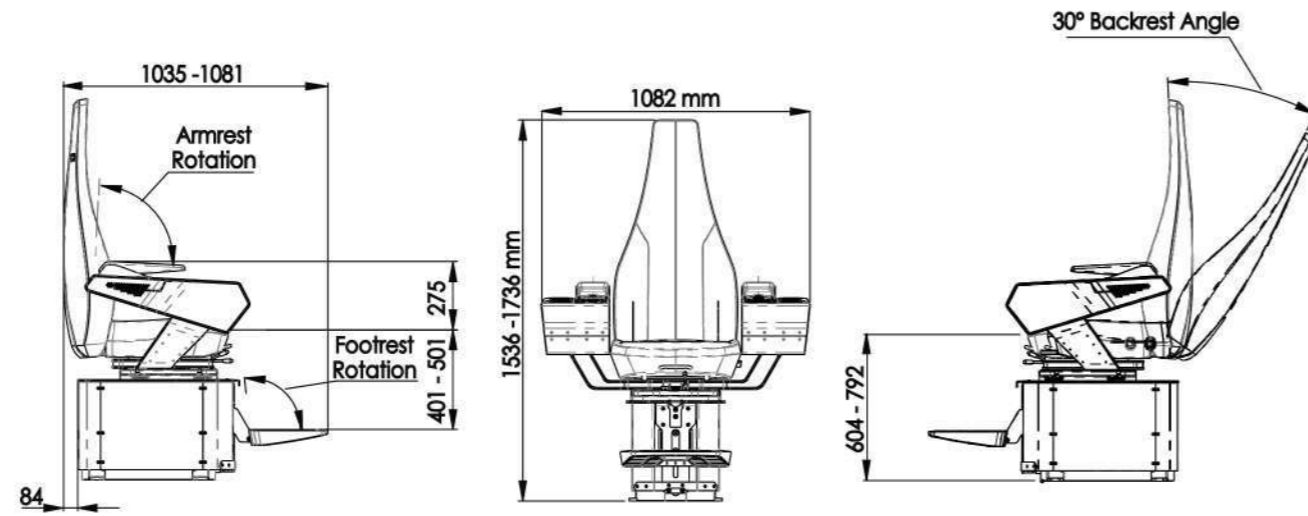

DESIGN AND FEATURES

- Reclining backrest
- Electric height adjustment
- Optional armrest sizes
- Adjustable and flip back armrest top
- Armrest suitable for equipment installation
- Fold up and height adjustable footrest
- Concealed and protected cable management
- OP chair is an "all in" chair suitable for DP, ROV, crane or other demanding operations
- Suitable either as "stand alone" units or installed on electric operated deck rails with cable management
- Available with hardback in high gloss finish

DECK RAIL OPTIONS



FLUSH MOUNT
ELETRICAL



SURFACE MOUNT
ELETRICAL



S12

Seat Innovation

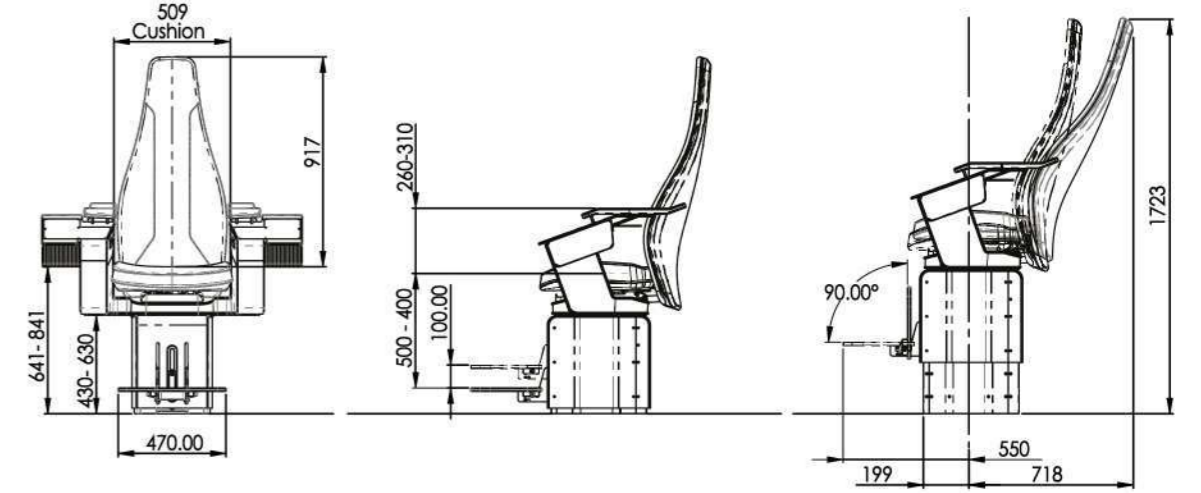

DESIGN AND FEATURES

- Electric reclining backrest
- Electric height adjustment
- Optional 6-way electric rotation
- Selection of 3 armrest sizes
- Armrests suitable for equipment installation
- Concealed and protected cable management
- Electric height adjustment of footrest
- Fold up footrest
- Optional 6-way electric adjustment of seat cushion
- Suitable either as "stand alone" units or installed on electric operated deck rails with cable management
- Available with hardback in high gloss finish

DECK RAIL OPTIONS



FLUSH MOUNT
ELETRICAL



SURFACE MOUNT
ELETRICAL



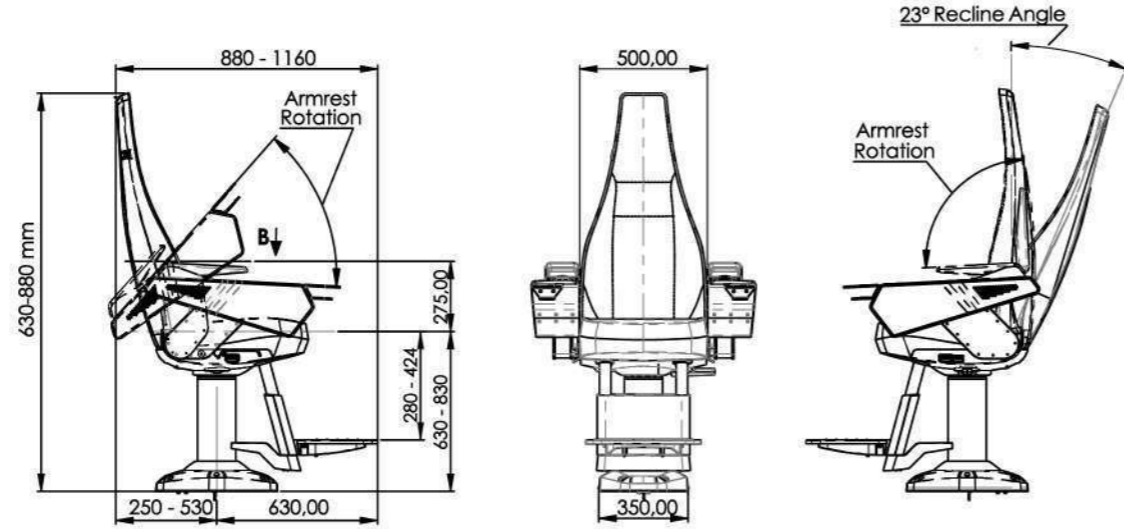

DESIGN AND FEATURES

- Reclining seat back
- Optional armrest sizes
- Adjustable and flip back armrest tops and complete arm
- Concealed and protected cable management
- Pneumatic height adjustment
- Shock absorbing column
- Armrest suitable for equipment installation
- Optional electric height adjustment
- Pneumatic height adjustment of footrest
- Fold up footrest
- Chair rotation
- Footrest rotates with chair and is supported by column for stability
- Available with hardback in high gloss finish
- HSC 2000 – Annex 10 approved

DECK RAIL OPTIONS



FLUSH MOUNT
ELETRICAL



SURFACE MOUNT
ELETRICAL



SURFACE MOUNT



FLUSH MOUNT

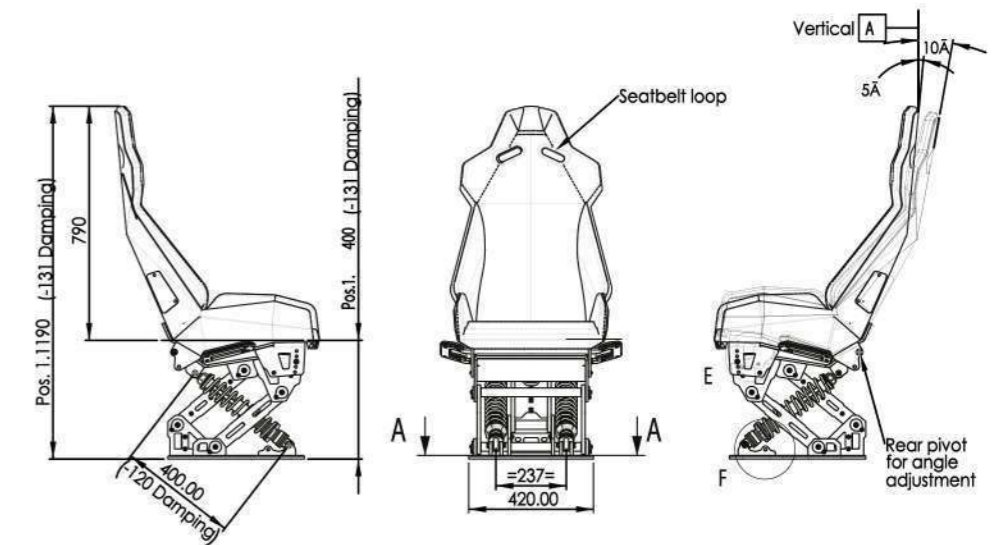

DESIGN AND FEATURES

- Seat constructed from 100% carbon
- Leather upholstery as standart
- Grip handles on both sides
- 4-point safety belt included
- Optional with armrest
- Optional with armrest attachments for control equipment
- Optional mounting base with custom made height
- Suitable for Navy, Coast Guard and other vessels operating high speed in all weather conditions
- The seat is designed for maximum protection and gives adequate support for safe and smooth travel
- HSC 2000 – Annex 10 approved



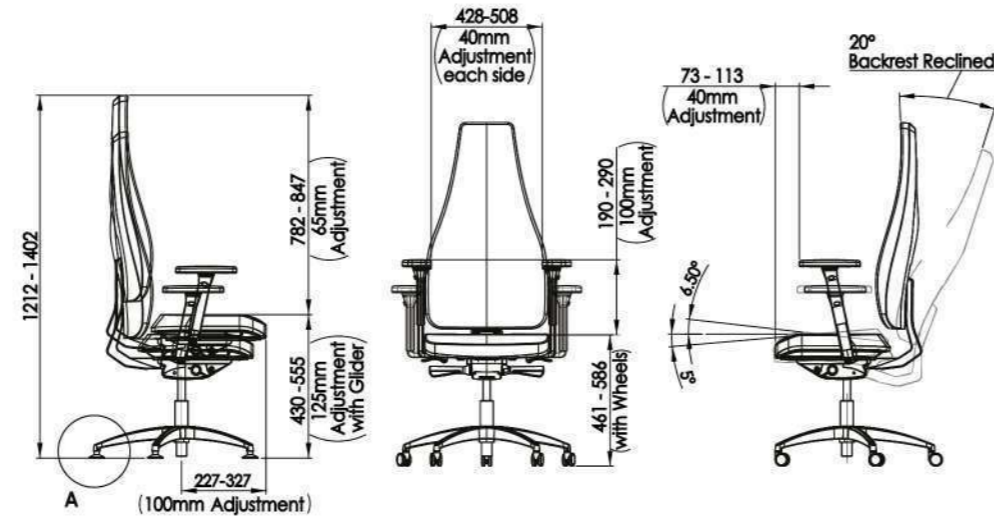

DESIGN AND FEATURES

- Reclining backrest
- Armrest adjustment forward and backward
- Armrest adjustment up and down
- Armrest width adjustment
- Seat adjustment forward backward
- Height adjustment
- Chair rotation
- Adjustable lumbar support
- Available with hardback in high gloss finish
- A comfortable office chair suitable for 24/7 operations with multiple ergonomic adjustment and design expression as our Alutech and OP series

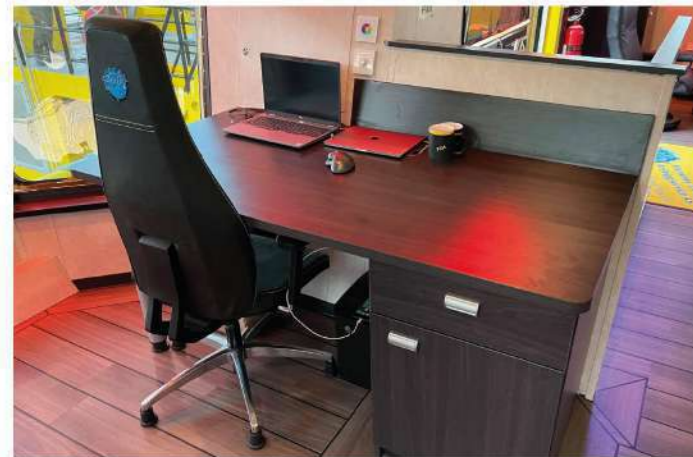

A wide variety of available accessories, not limited to cup holders, joystick boxes, safety belts, flip-out table, custom branding, intercom, seat covers and much more.



BESPOKE SOLUTIONS

Not all seating requirements are exactly the same; hence Alu Design offers a wide variety of custom built products. We pride ourselves in working closely with our clients to produce unique and innovative design solutions that can fulfill the most complex of user needs.



MANUAL DECK RAILS



SURFACE MOUNT



FLUSH MOUNT

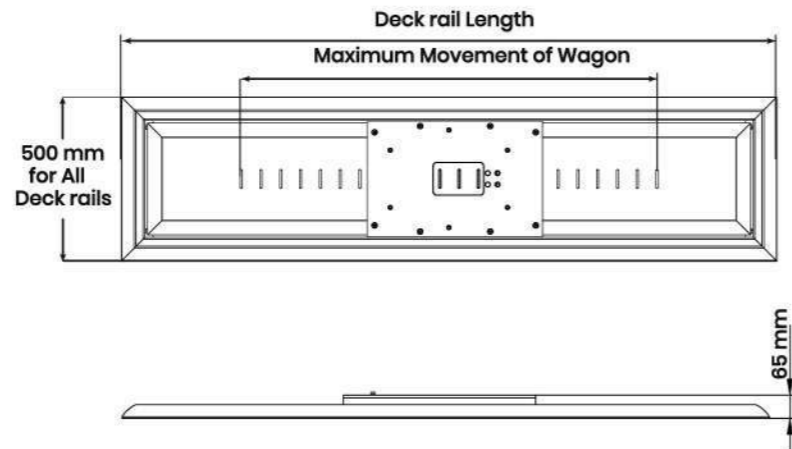

DESIGN AND FEATURES

- Simple to install
- Low weight - from 18 kg
- HSC 2000 - Annex 10 approved
- Available in 4 different lengths: 1500/2000/2500/3000 mm
- Can be made-to-fit in required length

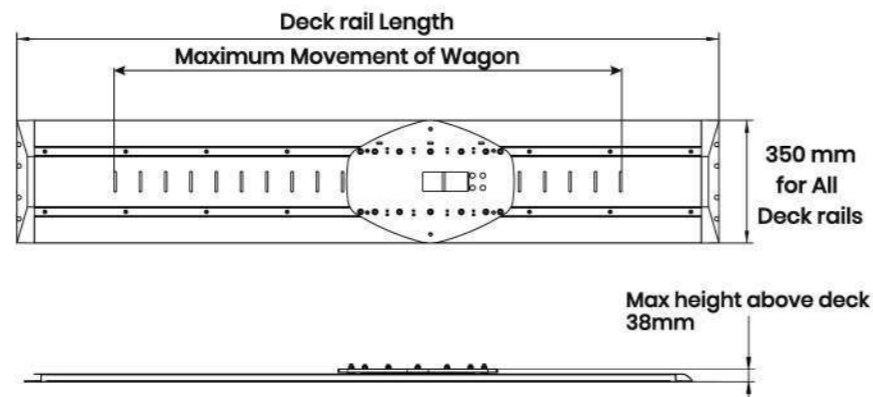

Detailed drawings online

ELECTRICAL DECK RAILS



SURFACE MOUNT ELECTRICAL

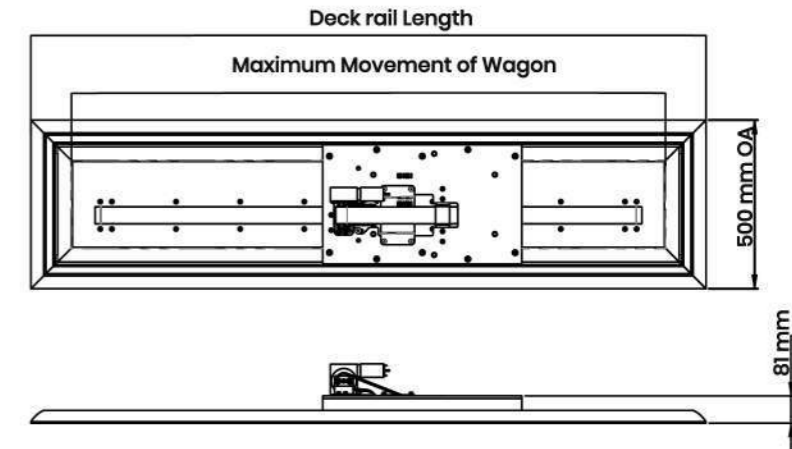

DESIGN AND FEATURES

- Surface mounted - without cable management
- Flush mounted - with cable management
- Low weight - from 37 kg
- Available in 4 different lengths: 1500/2000/2500/3000 mm
- Can be made-to-fit in required length
- HSC 2000 - Annex 10 approved

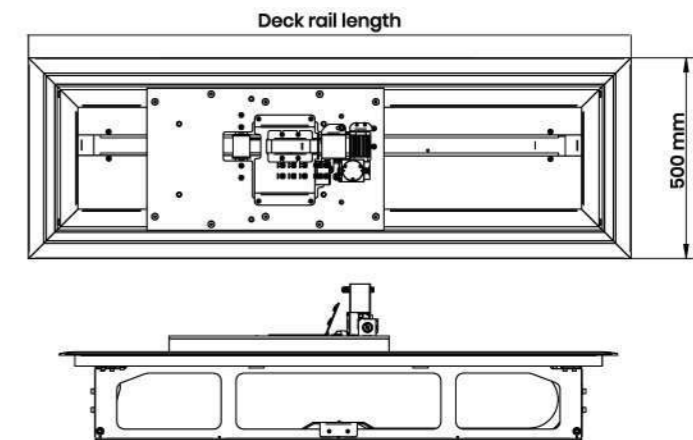

Detailed drawings online



FLUSH MOUNT ELECTRICAL



Captain Marvel

Marvel Studios' Captain Marvel takes you on a spectacular adventure from the 1990s, tracing the path of Carol Danvers (Brie Larson) as she becomes one of the most powerful heroes in the universe. When a galactic war reaches Earth, she

[▶ Play](#) [ⓘ More Info](#)

You May Also Like



When we develop a new high-tech operator and pilot chair we do it to meet the future – the best chair for any crucial job.

Paramount Pictures, the producers of the blockbusters Transformers and Star Trek movies, were looking for furniture with breath-taking, futuristic designs to help bring their stories to life. And the MH OCH 300 caught their eye as the perfect Sci-Fi object.

Our very own OP series, featured in the hit Hollywood movie "Hitman's Wife's Bodyguard" starring Salma Hayek, Ryan Reynolds, Samuel L. Jackson, Antonio and Morgan Freeman.

ALU jumped at the opportunity of imprinting the big screen with cutting-edge design. Onboard the super-yacht, amongst the most intense scenes, the OP chair adds composure and class.

You cannot miss the OP series chairs' futuristic play.



BAHAMA STD

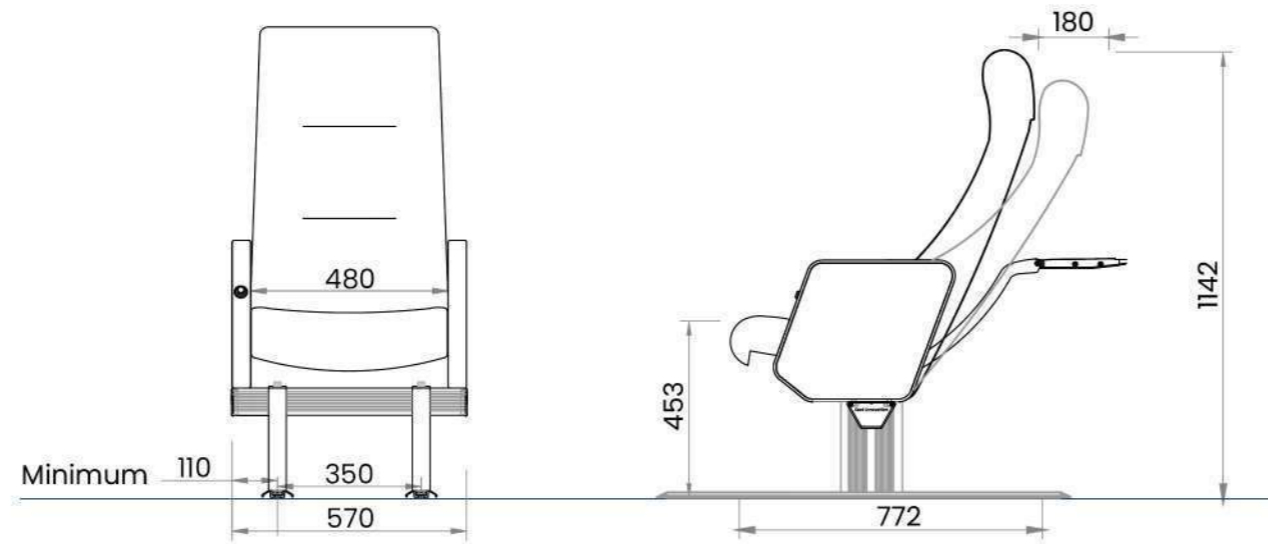

Bahama STD		Armrests 45 mm							
Seats	Configuration	0	1	2	3	4	5	6	
	1 - seat row	480	525	570					
	2 - seat row	960	1005	1050	1095				
	3 - seat row	1440	1485	1530	1575	1620			
	4 - seat row	1920	1965	2010	2055	2100	2145		
	5 - seat row	2400	2445	2490	2535	2580	2625	2670	

DESIGN AND FEATURES

The "Bahama Std" is designed to give passengers a best possible seating experience during the voyage. Comfortable features such as reclining and high back are standard.

Options: electric reclining, footrest, table on back of seat, closed armrest of 45 mm or 90 mm width, armrest with retractable table, stylish wooden armrest tops, USB and power outlets, newspaper pocket, integrated lifejacket box, versatile mounting options for deck placement.

Approved according to HSC-2000-Annex 10, level 1 and 2: gcoll up to 12g.



BAHAMA HS

Seat Innovation

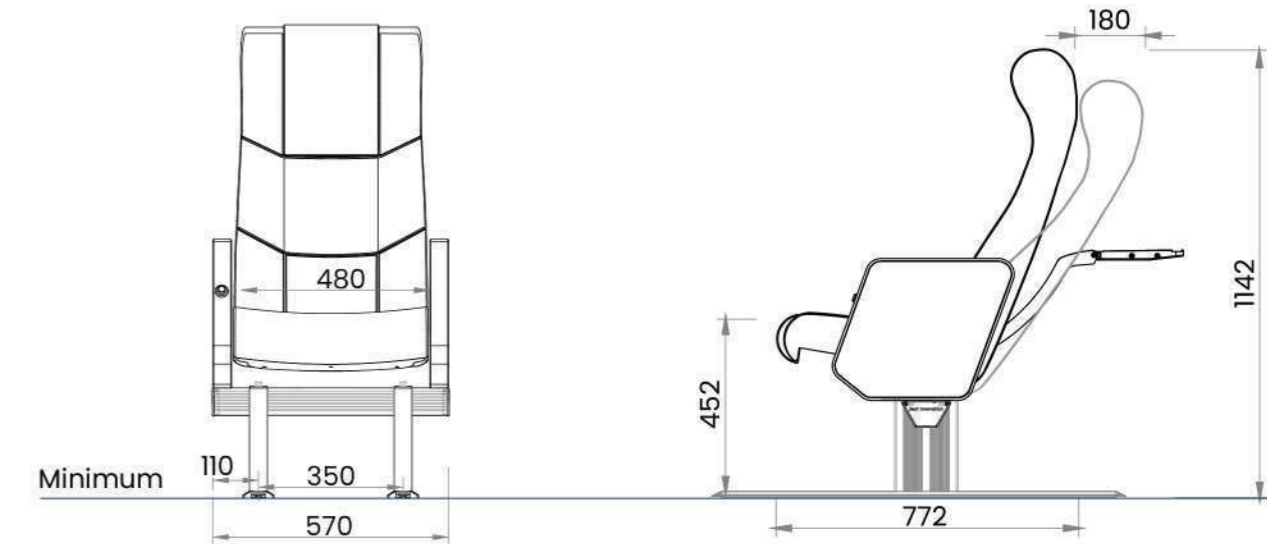

Bahama HS		Armrests 45 mm							
Seats	Configuration	0	1	2	3	4	5	6	
	1 - seat row	480	525	570					
	2 - seat row	960	1005	1050	1095				
	3 - seat row	1440	1485	1530	1575	1620			
	4 - seat row	1920	1965	2010	2055	2100	2145		
	5 - seat row	2400	2445	2490	2535	2580	2625	2670	

DESIGN AND FEATURES

The "Bahama HS" is designed to offer passengers the ultimate seating experience during their voyage. With standard features including reclining down to 45 dgr., high back support, and comfortable headrest, it has become one of our most sought-after seats.

Options: electric reclining, footrest, table on back of seat, closed armrest of 45 mm or 90 mm width, armrest with retractable table, stylish wooden armrest tops, USB and power outlets, newspaper pocket, integrated lifejacket box, versatile mounting options for deck placement.

Approved according to HSC-2000-Annex 10, level 1 and 2: gcoll up to 12g.



BAHAMA DIPLOMAT

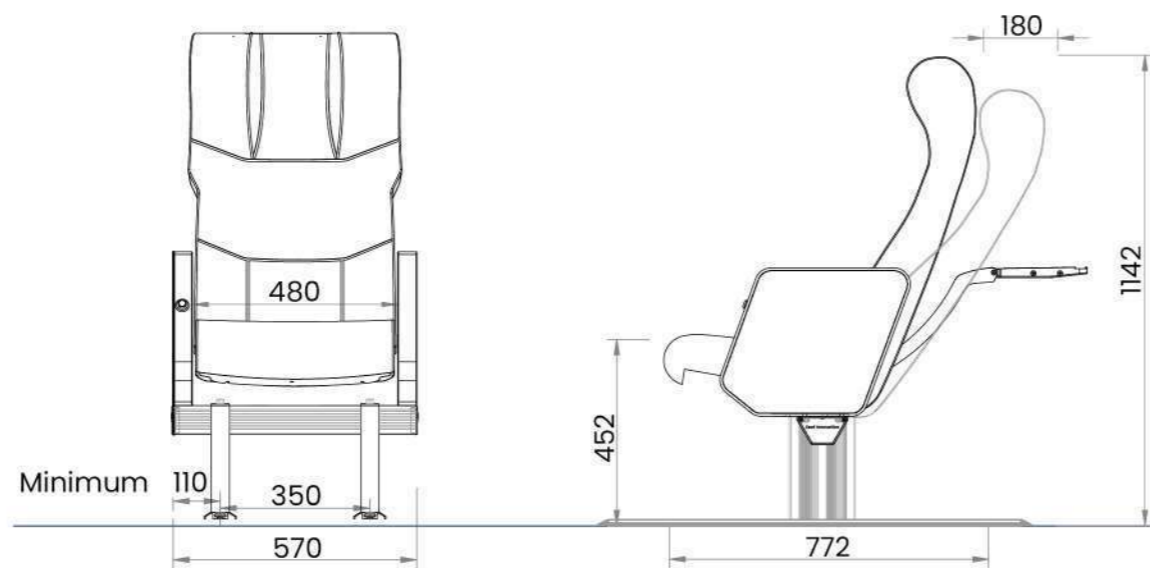

Bahama Diplomat		Armrests 45 mm							
Seats	Configuration	0	1	2	3	4	5	6	
	1 - seat row	480	525	570					
	2 - seat row	960	1005	1050	1095				
	3 - seat row	1440	1485	1530	1575	1620			
	4 - seat row	1920	1965	2010	2055	2100	2145		
	5 - seat row	2400	2445	2490	2535	2580	2625	2670	

DESIGN AND FEATURES

The "Bahama Diplomat" has the same high comfort and design standard as "Bahama Extended" but provides better space utilization. The "Bahama Diplomat" offers reclining possibilities down to 45dgr.

Options: electric reclining, footrest, table on back of seat, closed armrest of 45 mm or 90 mm width, armrest with retractable table, stylish wooden armrest tops, USB and power outlets, newspaper pocket, integrated lifejacket box, versatile mounting options for deck placement.

Approved according to HSC-2000-Annex 10, level 1 and 2: gcoll up to 12g.



BAHAMA EXTENDED

Seat Innovation

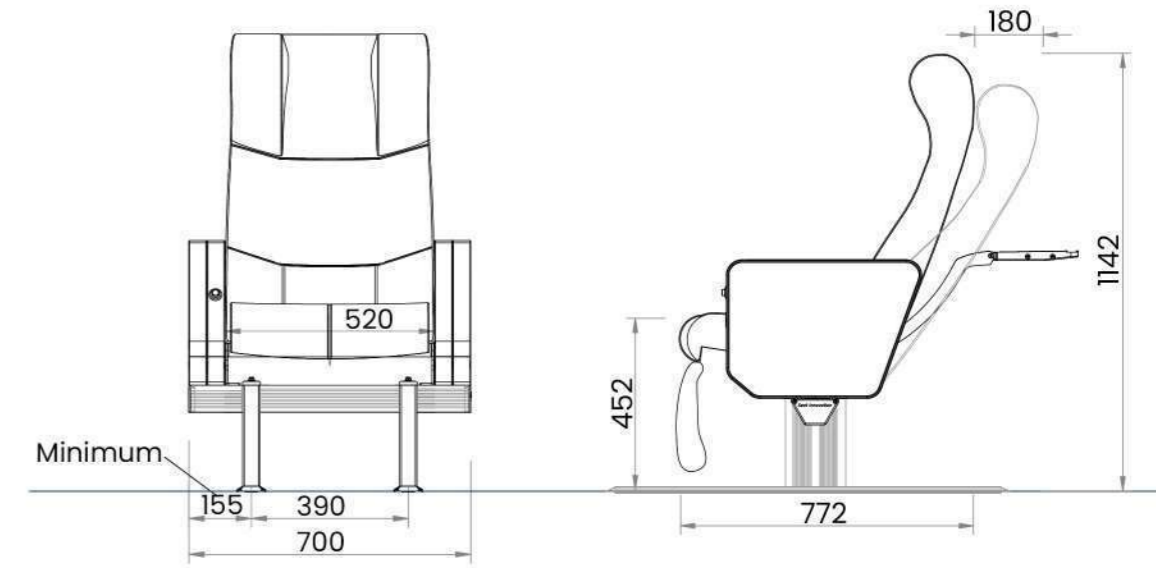

Bahama Extended		Armrests 45 mm							
Seats	Configuration	0	1	2	3	4	5	6	
	1 - seat row	520	610	700					
	2 - seat row	1040	1130	1220	1310				
	3 - seat row	1560	1650	1740	1830	1920			
	4 - seat row	2080	2170	2260	2350	2440	2530		
	5 - seat row	2600	2690	2780	2870	2960	3050	3140	

DESIGN AND FEATURE

The "Bahama Extended" is a business or first class seat that offers extra comfort for passengers with a design allowing a more spacious seating than standard. A passenger seat for those with higher expectations! The "Bahama Extended" offers reclining possibilities down to 45 dgr.

Options: electric reclining, footrest, table on back of seat, closed armrest of 45 mm or 90 mm width, armrest with retractable table, stylish wooden armrest tops, USB and power outlets, newspaper pocket, integrated lifejacket box, versatile mounting options for deck placement.

Approved according to HSC-2000-Annex 10, level 1 and 2: gcoll up to 12g



BAHAMA EDGE

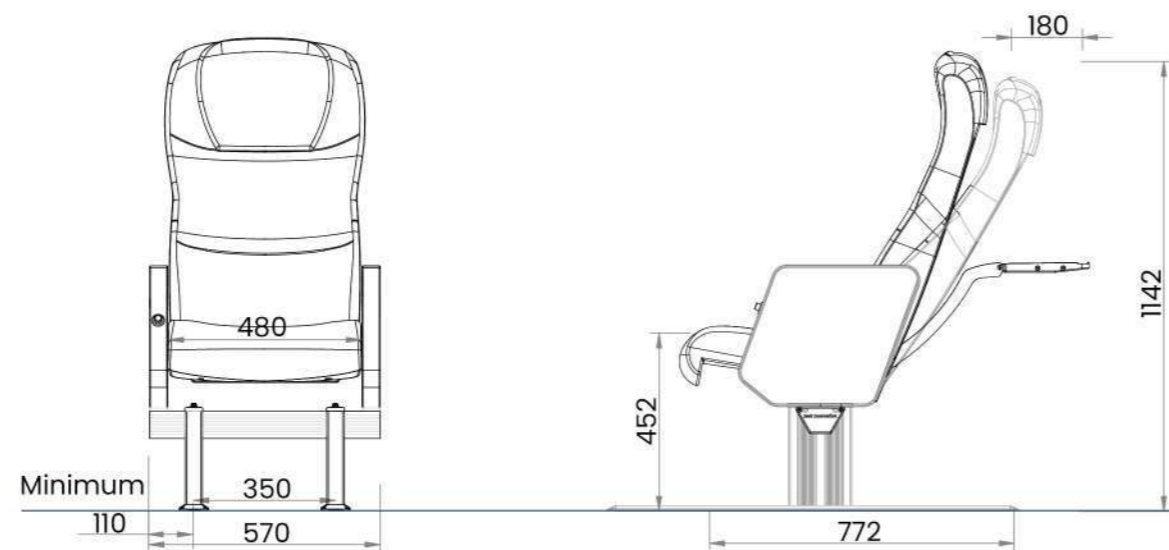

Bahama Edge		Armrests 45 mm							
Seats	Configuration	0	1	2	3	4	5	6	
	1 - seat row	480	525	570					
	2 - seat row	960	1005	1050	1095				
	3 - seat row	1440	1485	1530	1575	1620			
	4 - seat row	1920	1965	2010	2055	2100	2145		
	5 - seat row	2400	2445	2490	2535	2580	2625	2670	

DESIGN AND FEATURES

The "Bahama Edge" is designed to give passengers a best possible seating experience during the voyage. With standard features including reclining down to 45 dgr., high back support, and comfortable headrest and smooth design, it ensures a comfortable journey.

Options: electric reclining, footrest, table on back of seat, closed armrest of 45 mm or 90 mm width, armrest with retractable table, stylish wooden armrest tops, USB and power outlets, newspaper pocket, integrated lifejacket box, versatile mounting options for deck placement.

Approved according to HSC-2000-Annex 10, level 1 and 2: gcoll up to 12g.



SENJA HS

Seat Innovation

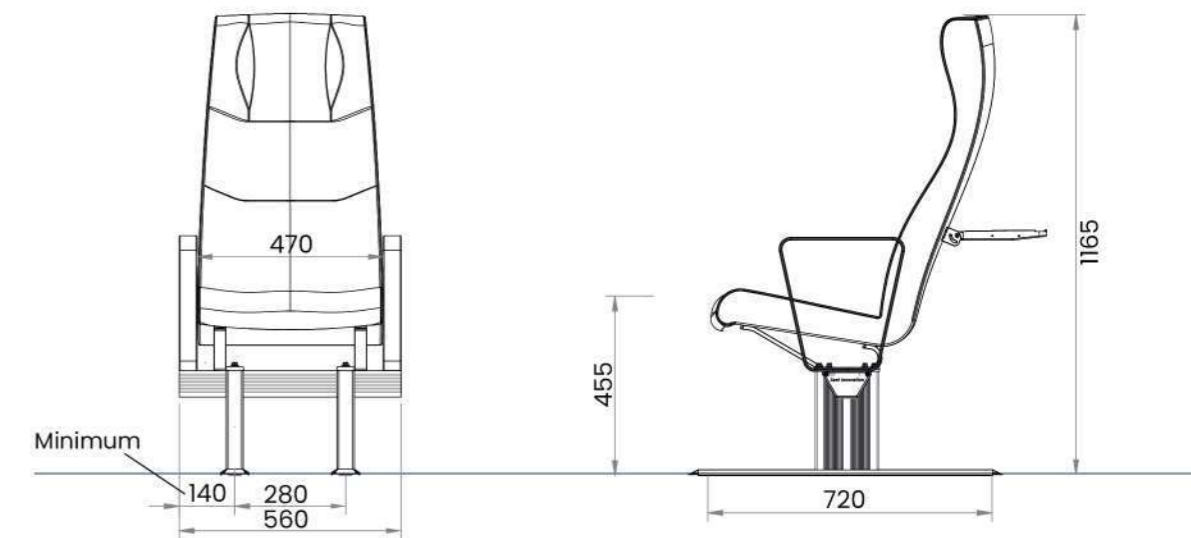

Senja HS		Armrests 45 mm							
Seats	Configuration	0	1	2	3	4	5	6	
	1 - seat row	470	515	560					
	2 - seat row	940	985	1030	1075				
	3 - seat row	1410	1455	1500	1545	1590			
	4 - seat row	1880	1925	1970	2015	2060	2105		
	5 - seat row	2350	2395	2440	2485	2530	2575	2620	

DESIGN AND FUTURES

The "Senja HS" series are designed to deliver maximum seating comfort while minimizing both cost and weight. With a high back and optional armrests, the 'Senja HS' offers customizable seating solutions tailored to individual preferences. It has become one of our most sought-after seats.

Options: table on back of seat, open or closed armrest of 45 mm or 90 mm width, armrest with retractable table, stylish wooden armrest tops, USB and power outlets, newspaper pocket, integrated lifejacket box, versatile mounting options for deck placement.

Approved according to HSC-2000-Annex 10, level 1 and 2: gcoll up to 12g.



SENJA HIGH

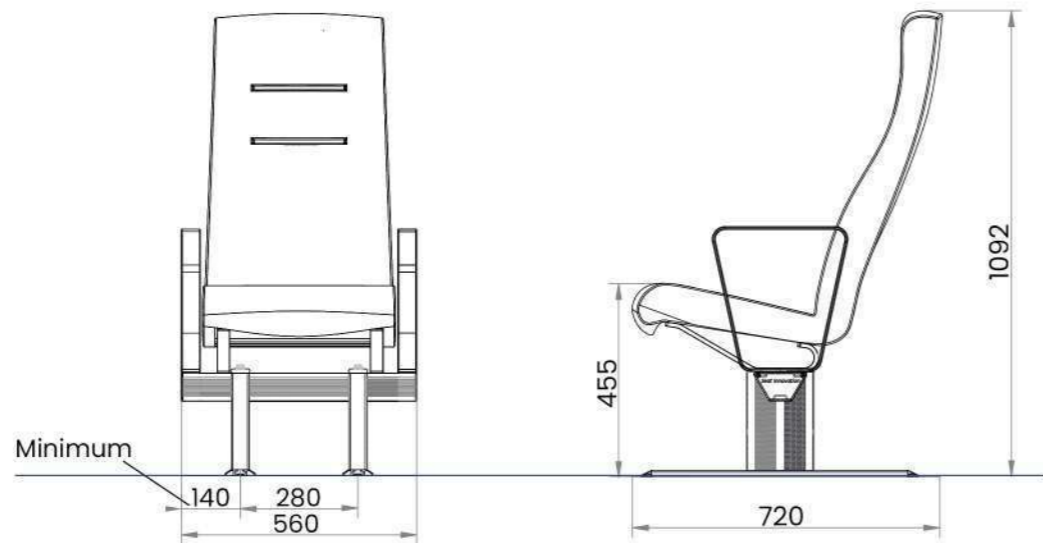

Senja High		Armrests 45 mm							
Seats	Configuration	0	1	2	3	4	5	6	
	1 - seat row	470	515	560					
	2 - seat row	940	985	1030	1075				
	3 - seat row	1410	1455	1500	1545	1590			
	4 - seat row	1880	1925	1970	2015	2060	2105		
	5 - seat row	2350	2395	2440	2485	2530	2575	2620	

DESIGN AND FEATURES

The "Senja High" series are designed with maximum seating comfort at a minimum cost and weight. The seats have fixed back and a comfortable ergonomic design. The "Senja High" has a high back. Armrests are optional.

Options: table on back of seat, open or closed armrest of 45 mm or 90 mm width, armrest with retractable table, stylish wooden armrest tops, USB and power outlets, newspaper pocket, integrated lifejacket box, versatile mounting options for deck placement.

Approved according to HSC-2000-Annex 10, level 1 and 2: gcoll up to 12g



SENJA MIDI

Seat Innovation

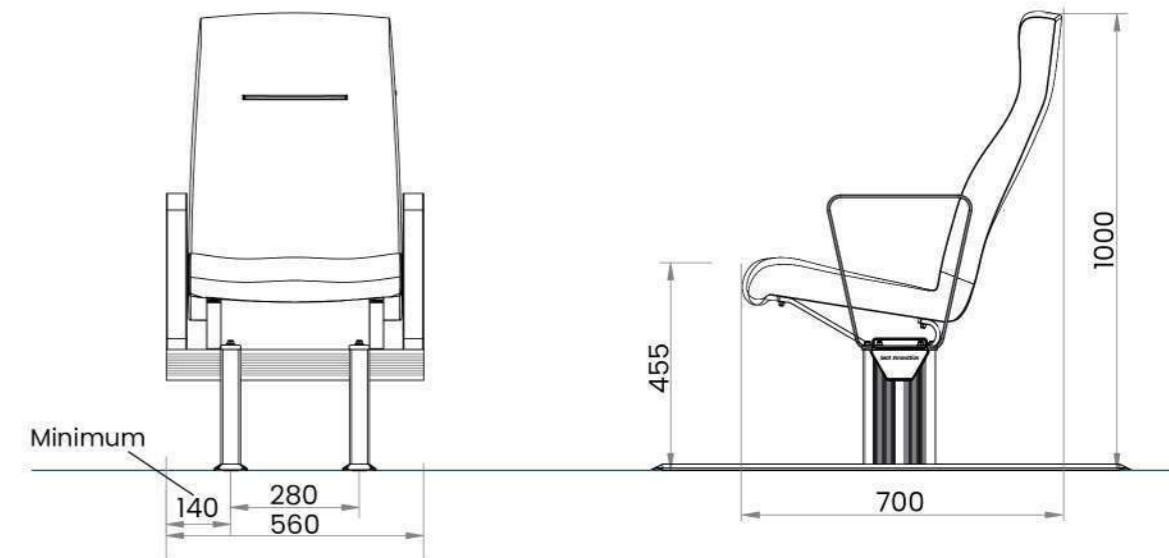

Senja Midi		Armrests 45 mm							
Seats	Configuration	0	1	2	3	4	5	6	
	1 - seat row	470	515	560					
	2 - seat row	940	985	1030	1075				
	3 - seat row	1410	1455	1500	1545	1590			
	4 - seat row	1880	1925	1970	2015	2060	2105		
	5 - seat row	2350	2395	2440	2485	2530	2575	2620	

DESIGN AND FEATURES

The "Senja Midi" series are designed with maximum seating comfort at a minimum cost. The seats have fixed back and a comfortable ergonomic design. The "Senja Midi" has a medium high back. Armrests are optional.

Options: table on back of seat, open or closed armrest of 45 mm or 90 mm width, armrest with retractable table, stylish wooden armrest tops, USB and power outlets, newspaper pocket, integrated lifejacket box, versatile mounting options for deck placement.

Approved according to HSC-2000-Annex 10, level 1 and 2: gcoll up to 12g.



SENJA CREW

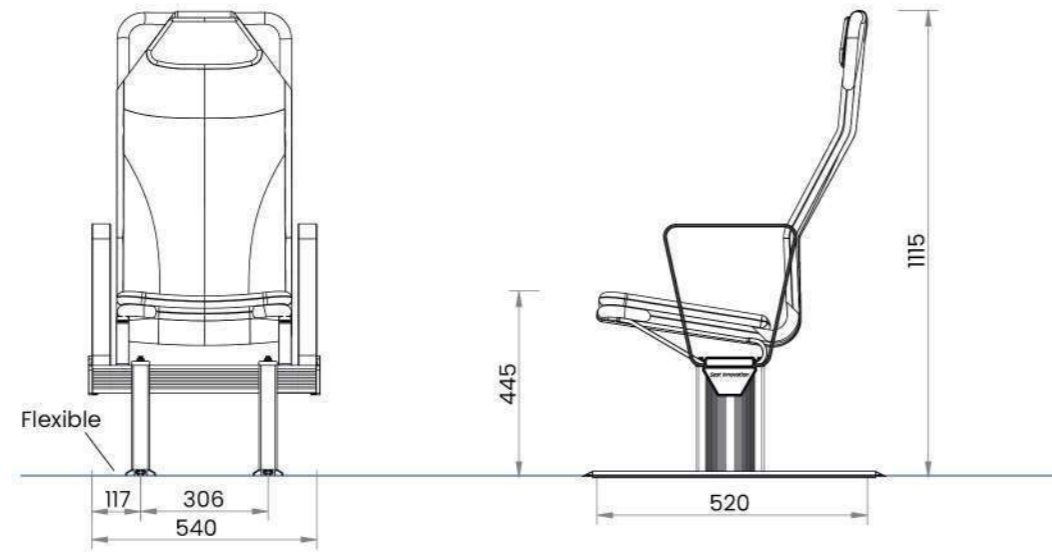

Senja Crew		Armrests 45 mm							
Seats	Configuration	0	1	2	3	4	5	6	
	1 - seat row	450	495	540					
	2 - seat row	900	945	990	1035				
	3 - seat row	1350	1395	1440	1485	1530			
	4 - seat row	1800	1845	1890	1935	1980	2025		
	5 - seat row	2250	2295	2340	2385	2430	2475	2520	

DESIGN AND FEATURES

The "Senja Crew" is an all-weather chair with removable easy to change fabric, mounted on the same beam and legs as the other chairs in Seat Innovation's range. Armrests are optional.

It is a lightweight seat approved according to HSC-2000-Annex 10, level 1: gcoll up to 3g.



OUTDOOR BENCHES



2 SEAT BENCH

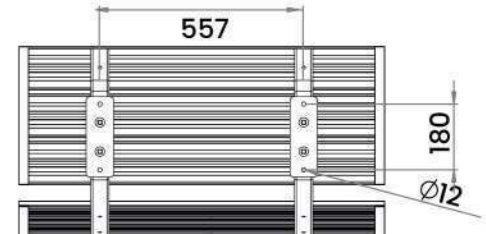
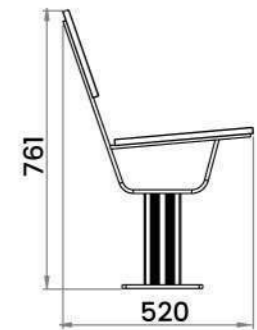
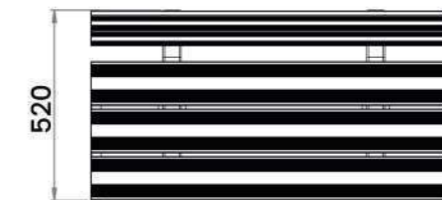
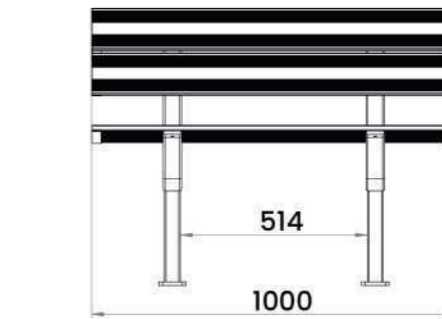

BENCH 150 CM LONG

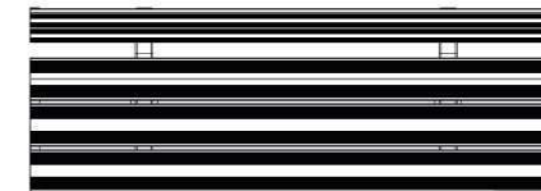
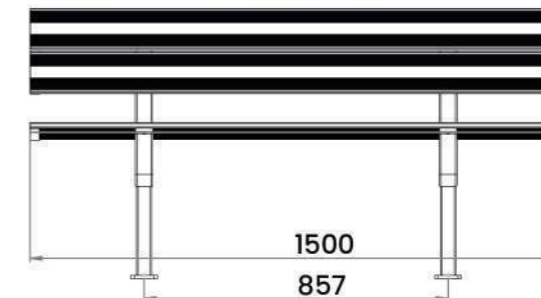

DESIGN AND FEATURES

The aluminium benches are designed for outdoor use and are resistant to environmental impacts.

The use of materials ensures lightweight construction.

Available in various lengths, including double benches back-to-back.



GENERAL CONTACT



info@seatinnovation.no
seatinnovation.no
Buråsen 42, 4636 Kristiansand, Norway

AGENTS



Our company is represented around the world by professionals. Please see contact details on our web for more information.

REFERENCES



Our products are found onboard all types of marine vessels worldwild. Check the long list of references on our website!



Seat Innovation

powered by

alu

Be seated.



MODELL
MØBLER
marine seating